

General Safety Information

⚠ WARNING

- Before use, check the wheels to make sure that there are no bent or loose spokes, dents, scratches or cracks on the rim surface. Do not use the wheel if any of these problems are found.
- This wheel is designed for use with trekking bikes. If the wheels are used excessively on unpaved surfaces, the wheels may become bent or damaged, and accidents may occur.
- Check that the wheels are fastened securely before riding the bicycle. If the wheels are loose in any way, they may come off the bicycle and serious injury may result.
- Obtain and read the service instructions carefully prior to installing the parts. Loose, worn, or damaged parts may cause injury to the rider. We strongly recommend only using genuine Shimano replacement parts.
- Read these Technical Service Instructions carefully, and keep them in a safe place for later reference.
- Be sure to read these service instructions in conjunction with the service instructions for the internal 8-speed hub before use.
- Be sure to carefully read the Service Instructions for the disc brakes also.

⚠ CAUTION

- The tires should be inflated to a suitable pressure before use.
- Use rim tape which can withstand high pressures, otherwise the tires may suddenly puncture and come off, and severe injury may result. Furthermore, it is not recommended that you reuse rim tape after it has been removed from the wheel. If the tape is reused, the tires may suddenly puncture and come off, and severe injury may result.

CAUTION

- Use of genuine Shimano spokes and nipples is strongly recommended.

Note

- If the wheel becomes stiff and difficult to turn, you should lubricate it with grease.
- Do not apply any oil to the inside of the hub, otherwise the grease will come out.
- We recommend that you ask authorized bicycle dealers to adjust the spoke tensions if there is any initial play in the spokes and after the first 1,000 km of riding.
- For maximum performance we highly recommend Shimano lubricants and maintenance products.
- Reflectors (manufactured by CATEYE) are also sold separately. Please ask your bicycle dealer for details.

Model number	Specification	Color
RR-317-WUA/4K SMN03	DIN	Amber
RR-550-WUW/W SMN03	CPSC	White
RR-550-WUA/A SMN03	AS	Amber

- If using a tube with a French valve, install the valve stem adapter that is included.
- Parts are not guaranteed against natural wear or deterioration resulting from normal use.

Technical Service Instructions

SI-4FH0A-001

WH-S501-8D

Rear Wheel
(with Internal 8-speed Hub)

In order to realize the best performance, we recommend that the following combination be used.

Applicable tire size	Clincher tire 700C (25C - 37C)
Rim size	700C (622 X 17C)

Specifications

Model number	WH-S501-8D
Speeds	Internal 8-speed
Rim size	700C (622 X 17C)
Rim width	23.2 mm

Spoke lacing

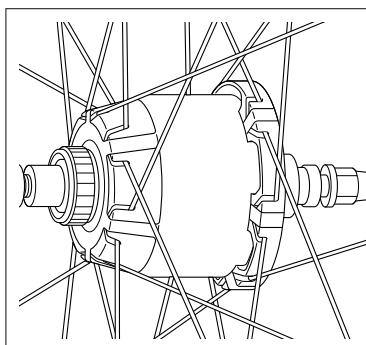

Lace the spokes as shown in the illustration.

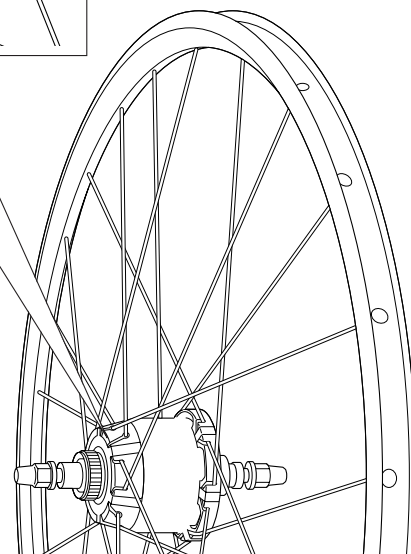

* These values should be used as a guide only.

Spoke tension value	
For rear	
Right (sprocket) side	Left side
900 - 1300 N (202 - 292 lbf)	700 - 1100 N (157 - 247 lbf)

SHIMANO

SHIMANO AMERICAN CORPORATION
One Holland, Irvine, California 92618, U.S.A. Phone: +1-949-951-5003

SHIMANO EUROPE B.V.
Industrieweg 24, 8071 CT Nunspeet, The Netherlands Phone: +31-341-272222

SHIMANO INC.
3-77 Oimatsu-cho, Sakai-ku, Sakai-shi, Osaka 590-8577, Japan

Please note: specifications are subject to change for improvement without notice. (English)
© Nov. 2006 by Shimano Inc. XBC SZK Printed in Malaysia.